

Superior bag housings designed for industrial and commercial filter applications with liquids.

The single bag liquid housings feature heavy-duty construction for maximum durability and are a reliable solution for pre, coarse, and bulk liquid filtration.

#1 and #2 bag housings:

- Available in 316L SS, 304L SS or carbon steel construction
- Clamp or swing bolt closures
- Stainless steel compression spring for positive bag sealing
- Adjustable stainless steel leg assembly
- 1/4" FNPT gauge ports and 1/2" FNPT drain port

#3 and #4 bag housings:

- 316 SS construction
- Clamp closure for easy bag change outs
- Adjustable leg assembly



L-BH SERIES

APPLICATIONS

- Water
- Food & Beverage
- Oil
- Coolants
- Chemicals
- Electronics
- Inks/Paints/Coatings
- Pulp & Paper

SPECIFICATIONS

MATERIALS	
Head / Shell #1 and #2 Sizes	316L SS, 304L SS, carbon steel
Head / Shell #3 and #4 Sizes	316L SS
Mounting Legs	304L SS
Gaskets	EPDM
Baskets	1/8" perforated stainless steel (various perforation and mesh sizes optional)

OPTIONS
Side Inlet / Side Outlet (#1 and #2 sizes)

See ordering guide for complete selection of options.

MAXIMUM OPERATING PRESSURE
150 psig (10.3 bar) @ 300°F (149°C)

CONNECTION TYPES	
Inlet/Outlet	2" FNPT (#1 and #2 sizes) 3/4", 1" and 1 1/2" FNPT (#3 and #4 sizes) Optional: RF flanges or sanitary ferrules
Drain Port	1/2" FNPT (#1 and #2 sizes)
Gauge Ports	1/4" FNPT - clean and dirty sides (#1 and #2 sizes)
Vent Port	1/4" NPT plug

DIMENSIONS

Bag Size	Closure	Max Flow Rate* GPM (LPM)	Drain Size	Dimensions				
				A	B	C	D	E
Size 1	Clamp or Swing Bolt	70 (265)	1/2"	18 7/8" (47.9 cm)	20 1/2" (52.1 cm)	21 3/4" (55.2 cm)	3" (7.6 cm)	6 11/16" (17.0 cm)
Size 2	Clamp or Swing Bolt	150 (567)	1/2"	34 7/8" (88.6 cm)	22 3/4" (92.7 cm)	21 3/4" (55.2 cm)	3" (7.6 cm)	6 11/16" (17.0 cm)
Size 3	Clamp	25 (95)		16 9/16" (42.1 cm)	10 3/8" (26.4 cm)			
Size 4	Clamp	40 (151)		22 7/8" (58.1 cm)	16 11/16" (42.4 cm)			

*Flow rates are guidelines only. Actual flow rates are based upon fluid, viscosity, bag type, micron ratings and other factors

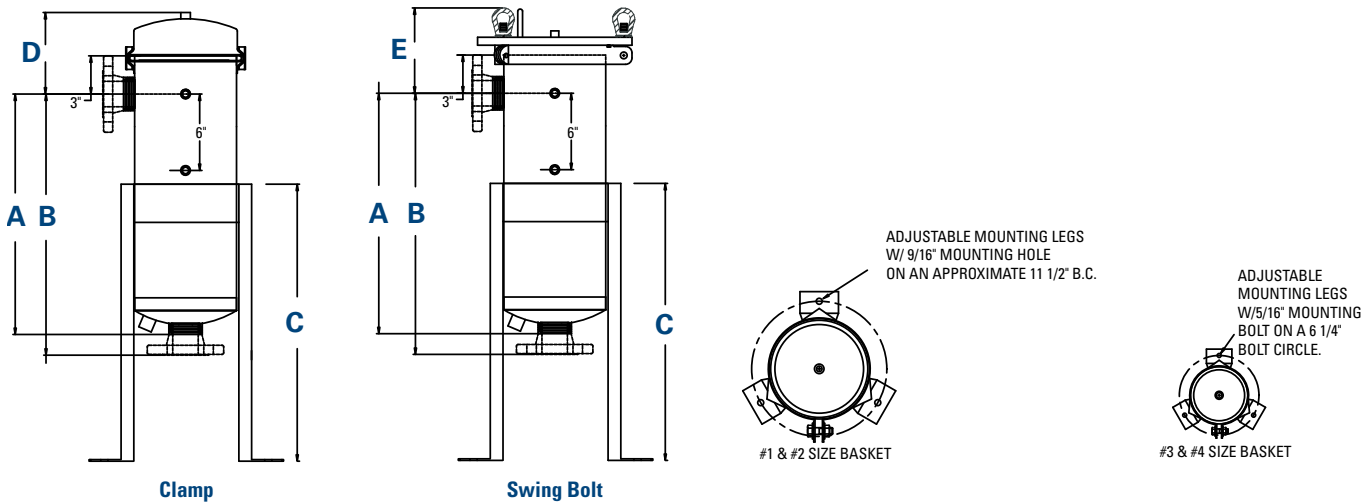

Product Selection

Bag Size	Material	Inlet/Outlet Connection	Closure Style	Gasket
1	304 SS	2" FNPT (standard)	Clamp	Buna
2	316 SS	2" RF Flange	Swing Bolt	EPR
		3" FNPT		Silicone
		3" RF Flange		Viton
		2" Sanitary		
3	316 SS	3/4" FNPT	Clamp	Buna
4		1" RF Flange		EPR
		1 1/2" FNPT		Silicone

*Note: 134 Coating must have swing bolt closure and flanged connections.

Customization

Housings may be customized to meet your precise requirements. Contact your Donaldson representative for more information.

Important Notice

Many factors beyond the control of Donaldson can affect the use and performance of Donaldson products in a particular application, including the conditions under which the product is used. Since these factors are uniquely within the user's knowledge and control, it is essential the user evaluate the products to determine whether the product is fit for the particular purpose and suitable for the user's application. All products, specifications, availability and data are subject to change without notice, and may vary by region or country.



Donaldson Company, Inc.
Process Filtration
Minneapolis, MN

donaldsonprocessfilters.com
shop.donaldson.com

North America 800-543-3634
Mexico 800-343-3639
Fax 952-885-4791
processfilters@donaldson.com



F117075 ENG (04/18) L-BH Series Single Bag Liquid Housings

© 2018 Donaldson Co., Inc. All Rights Reserved. Donaldson and the color blue are marks of Donaldson Company, Inc. All other marks belong to their respective owners.
{Contains Donaldson proprietary technology.}